

Acorn 130 Perch

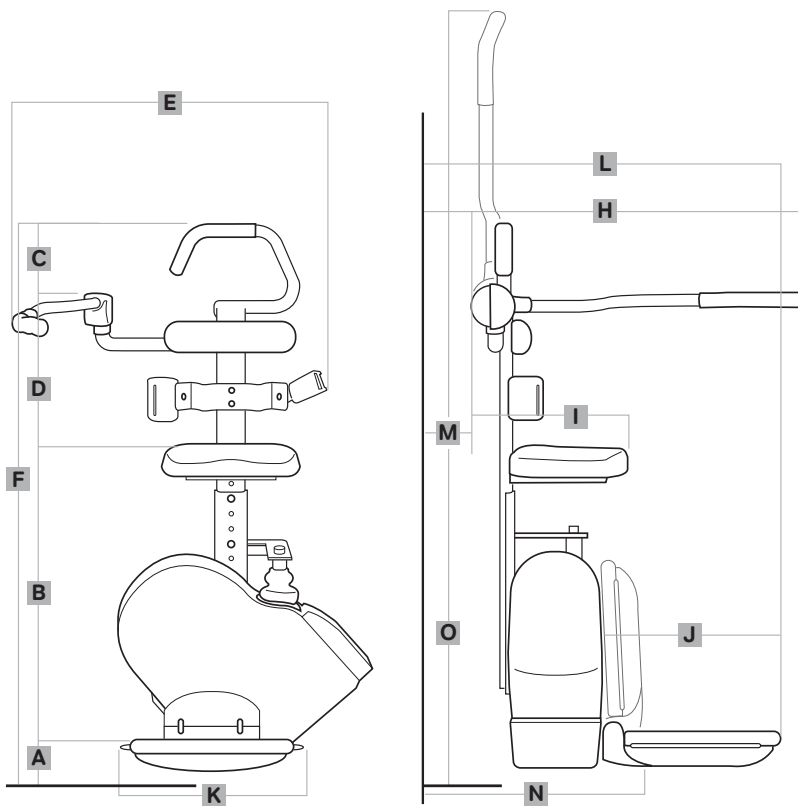

Angles

Min - 33°

Max - 45°

Specifications

Dimensions

	mm	inch
A Floor to top of footrest	95	3¾
B Top of footrest to top of seat	525 (L) 695 (H)	20¾ (L) 27¼ (H)
C Top of seat to top of handrail down	380	15
D Top of arm to top of seat back / handrail	100	4
E Overall width from seatbelt to outer hand rail	615	24¼
F Overall height to seat back / handrail	1100 (L) 1270 (H)	43¼ (L) 50 (H)
H Overall depth with grab rail down (from wall)	630	24¾
I Length of seat base from seat back	320	12½
J Length of footrest	325	12¾
K Width of footrest	310	12¼
L Front of footrest to stringer	585	23
M Back of seat to stringer	13	½
N Folded width	310	12¼
O Overall height with grab rail up	1580 (L) 1750 (H)	62¼ (L) 69 (H)
P Distance from front of rail to stringer	230	9

(L) Lowest height set (H) Highest height set

Power supply input range 120 - 240v AC

Carriage power 24v DC batteries

Motor Power 0.25KW

Maximum Capacity 127kgs

Motor Output Speed No greater than 0.15 m/s

Method of Drive Rack and Pinion

Measurements are only a guide and subject to site and client survey.